

## SERIES

# ML200-D1000



## Highlights

- Galvanized hot dip powder coated frame
- Triplex carbide plunger pump
- Deutz robust air-cooled/water cooled turbo charged diesel engine
- Stainless Steel Water tank with low-Water level cut off function for pump protection
- Stainless steel pressure gauge with glycerin
- Stainless steel filter housing with 5 microns water filter with replaceable filters
- Control panel with emergency stop and function indicator
- Heavy duty Booster Pump

# Marlin

## High Pressure Water Blaster

### 1000bars

*Marlin* **ML200-D1000 Series** is a professional heavy duty high-pressure water blaster with a high-performance crank shaft, ceramic pistons and the simplest design aimed to reduce the Total Cost of Ownership (TCOO). Fully manufactured in Europe, these water blasters are designed to reduce the complexity of maintenance without compromising the quality and durability for heavy duty usage under the toughest conditions.

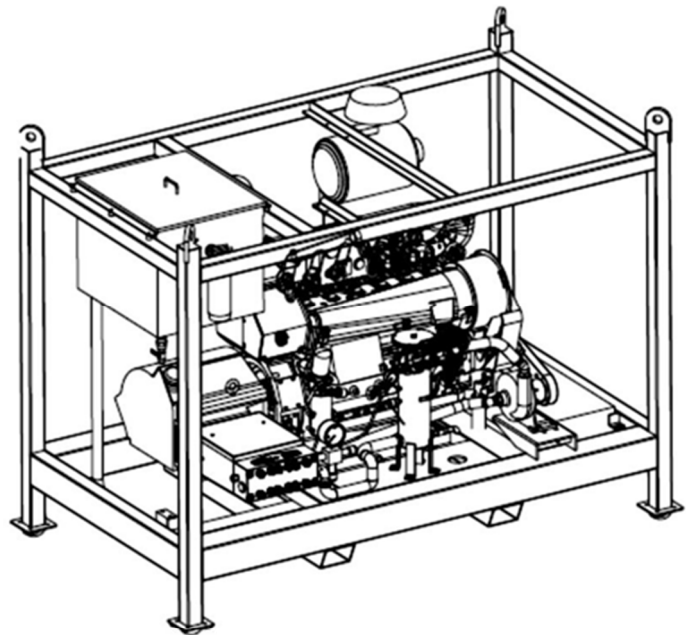

Triplex Plunger Pump



SS Water Filter Housing



Booster Pump

## SERIES

# ML200-D1000

### Optional Accessories

- Extension hoses with connectors
- Dump/pneumatic trigger guns with lance
- Self-Rotating nozzle
- Drain and pipe cleaning nozzles
- Spare part kits
- Cold cutting equipment
- High pressure protect clothing, helmet with face shield and earmuff
- High pressure Hose and hose protection

# Marlin

### Optional Accessories



Trigger Dump Gun



Rotating Nozzle



UHP Hoses



Pneumatic Gun



Tumble Box



Surface Cleaner

### Technical Specifications

ML200-D1000

Pump Pressure (Bar/Psi)	1000/14504
Flowrate (liter per minute)	63
Max inlet temperature (°C)	35
Drive	Deutz 6 Cylinder Turbo
Power consumption (HP/kW)	150/110
Pump inlet RPM	1500/1800
Weight (Kg)	1800
Dimension (mm)	2500 x 1500 x 1950

### Contact us

#### Email

[sales@olsomens.com](mailto:sales@olsomens.com)

#### Website

[www.olsomens.com](http://www.olsomens.com)